

# Datasheet

## EASYLOCK® Filters

Protection against Gas, Vapour & Dust



### For Series 7000 and 9000 masks



#### Gas filters

<b>9100</b> A1	<b>9400</b> ABEK1
<b>9200</b> A2	<b>9500</b> A2B2E1
<b>9300</b> ABE1	<b>9600</b> AX



#### Particulate filters

<b>9010</b> P1 R
<b>9020</b> P2 R
<b>9022</b> P2 R+Ozone
<b>9030</b> P3 R
<b>9032</b> P3 R+Ozone



#### Pre-assembled filters

<b>9120</b> A1P2 R
<b>9230</b> A2P3 R
<b>9430</b> ABEK1P3 R
<b>9730</b> ABEK1HgP3 R D

### EASYLOCK® filter system

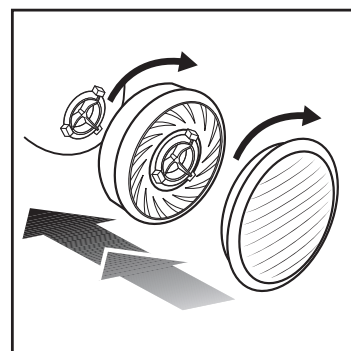
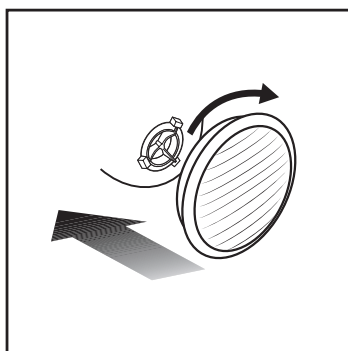
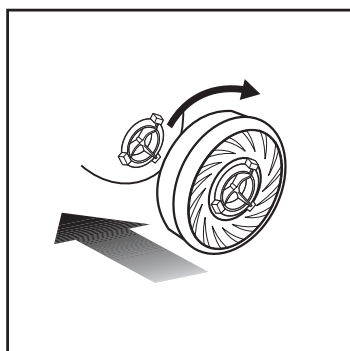

#### CHARACTERISTICS

- Particulate filters can either be directly combined with the EasyLock® gas cartridges or directly connected with the mask body.
- Easy handling as no adapters or particulate filter holders are necessary with the Moldex EasyLock®-System.
- The unique Moldex Pleated Filter Technology reduces breathing resistance and considerably increases the capacity of the particulate filters.
- The pre-assembled filter combinations offer the simplicity of combined filters and are more economical at the same time due to exchangeable pre-filters.
- Simpler logistics, on average 30% less parts are required with the EasyLock®-System.
- 100% PVC-FREE: All Moldex products and packaging are 100% PVC-free

#### CERTIFICATION

The EasyLock® filters meet the requirements of EN 14387:2004 + A1:2008 and EN 143:2000 + A1:2006 and are CE-marked in accordance with the requirements of European Directive 89/686/EEC. The Institut für Arbeitsschutz IFA (BGIA) in St Augustin (0121) in Germany is the body responsible for both type examination (article 10) and monitoring of products (article 11). The products are manufactured in an ISO 9001:2000 certified plant.

#### MATERIAL

**Particulate filter:** Polypropylene  
**Particulate filter 9022, 9032:** Active Charcoal  
**Particulate filter holder:** Polypropylene  
**Gas filter:** Active Charcoal  
**Gas filter cartridge:** Polypropylene

#### WEIGHT (apiece)

<b>9100:</b> 66 g	<b>9600:</b> 112 g	<b>9032:</b> 27 g
<b>9200:</b> 87 g	<b>9010:</b> 18 g	<b>9120:</b> 84 g
<b>9300:</b> 67 g	<b>9020:</b> 18 g	<b>9230:</b> 117 g
<b>9400:</b> 92 g	<b>9022:</b> 24 g	<b>9430:</b> 122 g
<b>9500:</b> 109 g	<b>9030:</b> 30 g	<b>9730:</b> 127 g

#### IMPORTANT INFORMATION FOR USERS

- The mask and the filters must be selected in accordance with the pollutant concentration. (see tables 1,2 and 3)
- In the case of gases with insufficient warning properties, filters may only be used if special usage policies are specified for this purpose.
- If the conditions are uncertain or changeable, a self-contained breathing apparatus must be worn.
- The product does not contain any metallic parts that could cause ignition in potentially explosive atmospheres.

# Datasheet

## EASYLOCK® Filters

Protection against Gas, Vapour & Dust



### SERVICE LIFE OF THE CARTRIDGES AND PARTICULATE FILTERS

If you can smell gases or vapours when you use the gas filters, they are exhausted and must be replaced (no later than 6 months after the original packaging is opened). Replace the particulate filter if the breathing resistance increases dramatically. The filters must always be replaced in pairs. You must adhere to the use-by-date.

### STORAGE

Keep the filters sealed in a dry, uncontaminated environment. Protect them against sunlight and sources of heat.

### FILTERS QUALIFY AS HAZARDOUS WASTE

They must be disposed of in accordance with the applicable waste disposal regulations. Information is provided by your local responsible authority.

### GAS FILTER MODEL EN 14387

table 1

Model	Colour	Area of application
A	Brown	Organic gases and vapours, boiling point > 65°C
B	Grey	Inorganic gases and vapours, boiling point > 65°C
E	Yellow	Acid gases (e.g. sulphur dioxide, hydrochloric acid)
K	Green	Ammonia
AX	Brown	Organic vapours boiling point ≤ 65°C
Hg P3	Red-White	Mercury

**CAUTION:** AX filters must only be used once. Low-boiling gases (≤ 65°C) generally bind poorly with gas filters. This may result in shorter periods in service. Please refer to the relevant national regulations for information about the maximum permissible application concentrations and times for the individual compounds. Only use with vapours with good warning properties.

AX filters do not offer adequate protection against various low-boiling gases. If you have any questions about how to use AX filters, please contact Moldex.

The filter 9730 ABEK1Hg P3 have a maximum use time of 50h against mercury.

### GAS FILTER CLASS EN 14387

table 2

Class	Maximum use level with half mask Series 7000	Maximum use level with full face mask Series 9000
1	1000 ppm (0.1 percent by volume) or 10 x WEL*	1000 ppm (0.1 percent by volume) or 20 x WEL*
2	5000 ppm (0.5 percent by volume) or 10 x WEL*	5000 ppm (0.5 percent by volume) or 20 x WEL*

\* WEL = Workplace Exposure Limit

whichever is lower

### PARTICULATE FILTER CLASS

EN 143:2000 + A1:2006

table 3

Class	Maximum use level with halfmask Series 7000	Maximum use level with fullmask Series 9000
P1 R	4 x WEL * not against carcinogenic and radioactive materials, not against micro-organisms and enzymes	4 x WEL * not against carcinogenic and radioactive materials, not against micro-organisms and enzymes
P2 R	10 x WEL * not against radioactive materials, viruses and enzymes	10 x WEL * not against radioactive materials, viruses and enzymes
P3 R	20 x WEL *	40 x WEL *
P2 R + P3 R + Ozone	In addition to the particle filtering efficiency these filters also offer protection against ozone; at 1000ppb ozone a maximum use time of 8h.	

\* WEL = Workplace Exposure Limit

**R:** The filters are reusable.

Due to the low weight of filters of less than 150 g per filter (-combination) all filters can be used for both, the full face mask and the half mask.

### Quality control and EC type-approval office:

IFA (BGIA); Identification number: 0121; 53757 Sankt Augustin; Germany

### INFO

For help on selection and training please contact us. We offer a wide range of training packages and support material.

MOLDEX-METRIC AG & Co. KG  
Unit 9, Glaisdale Point  
Off Glaisdale Drive, Bilborough  
Nottingham. NG8 4GP

Tel.: +44 (0)115 985 4288  
Fax: +44 (0)115 985 4211  
info@uk.moldex-europe.com  
www.moldex-europe.com